

ELABORATO GRAFICO 1

LOTTO 2

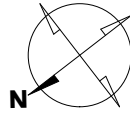

PIANTA QUOTATA APPARTAMENTO B - CANTINOLA B.1

VIA G. DELEDDA

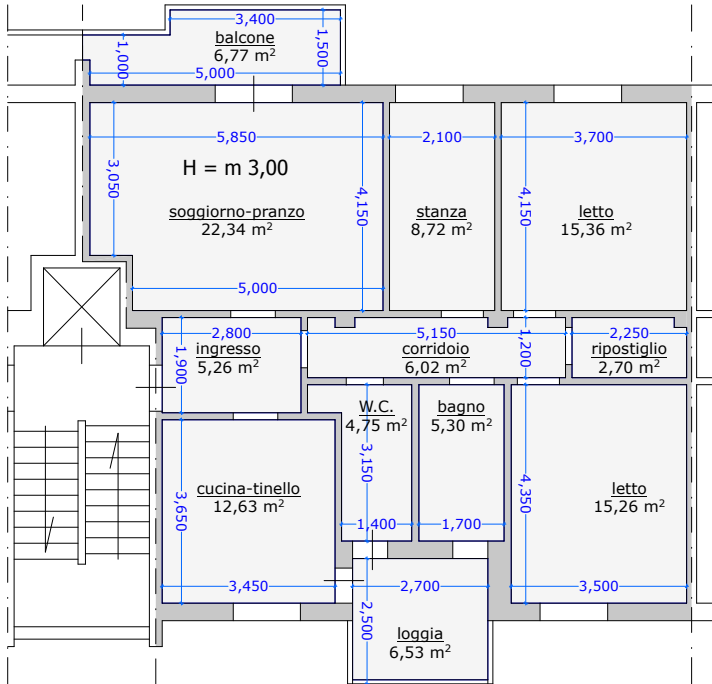

CORILE CONDOMINIALE

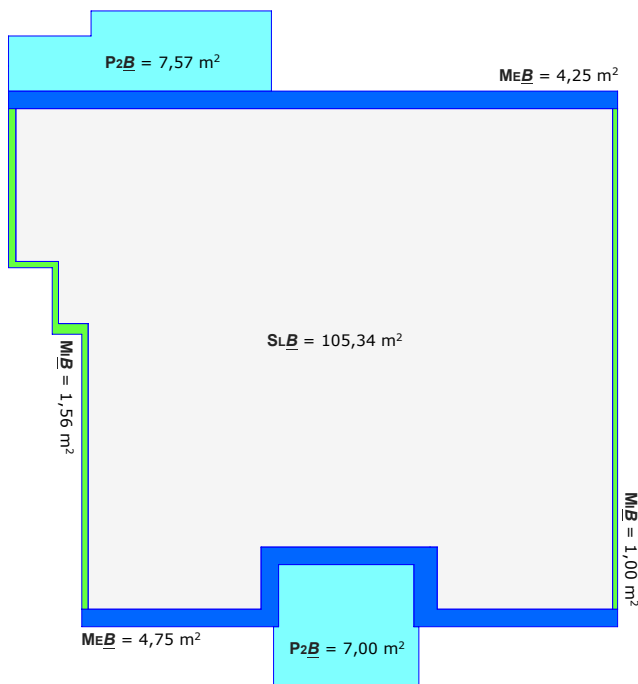
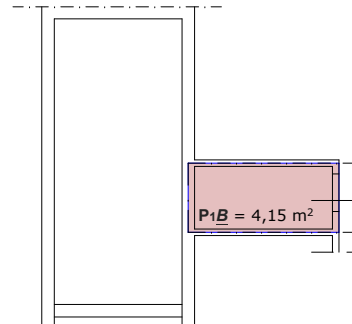
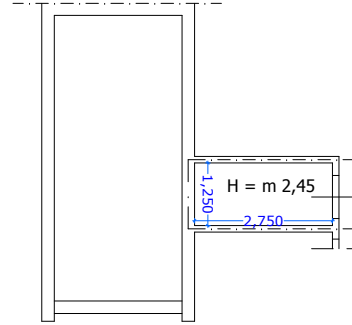

CALCOLO DELLA SUPERFICIE COMMERCIALE APPARTAMENTO B CON CANTINOLA B.1

SRB = Superfici Reali **B**:

SLB

SLB = Superficie Abitabile Utile Lorda = mq 105,34;

MEB

MEB = 100% Superficie murature perimetrali esterne (spessore Max m 0,50) = mq (4,75 + 4,25) = mq 9,00;

MiB

MiB = 50% Superficie murature perimetrali interne (spessore Max m 0,25) = mq (1,56 + 1,00) = mq 2,56;

P1B

SRB = **SLB** + **MEB** + **MiB** = mq 116,90

P2B

SVB = Superfici Virtuali (pertinenze esclusive dirette di servizio e ornamento x coeff. di omogeneizzazione):

SvSB = 50% **SP1B** = mq 2,08

MEB = 1,00 m²

SvPB = 30% **SvP2B** = mq 30%*(7,57 + 7,00) = mq 4,37;

SVB = **SvSB** + **SvPB** = mq 6,45

SCB = Superficie Commerciale = **SRB** + **SVB** = mq (116,90 + 6,45) = mq 123,35

SCB = Superficie Commerciale **B** = mq 123,00