

DOCUMENTAZIONE FOTOGRAFICA
LOTTO 1 - IMMOBILE A
fig. 72 pct. 250 sub 1 – Via Lazio n. 8



DOCUMENTAZIONE FOTOGRAFICA
LOTTO 1 - IMMOBILE A
fig. 72 pct. 250 sub 1 – Via Lazio n. 8



DOCUMENTAZIONE FOTOGRAFICA
LOTTO 1 - IMMOBILE A
fig. 72 ptc. 250 sub 1 – Via Lazio n. 8



DOCUMENTAZIONE FOTOGRAFICA
LOTTO 1 - IMMOBILE A
fig. 72 pct. 250 sub 1 – Via Lazio n. 8



DOCUMENTAZIONE FOTOGRAFICA
LOTTO 1 - IMMOBILE A
fig. 72 pct. 250 sub 1 – Via Lazio n. 8



DOCUMENTAZIONE FOTOGRAFICA
LOTTO 1 - IMMOBILE A
fg. 72 pct. 250 sub 1 – Via Lazio n. 8



DOCUMENTAZIONE FOTOGRAFICA
LOTTO 1 - IMMOBILE A
fig. 72 pct. 250 sub 1 – Via Lazio n. 8



DOCUMENTAZIONE FOTOGRAFICA
LOTTO 1 - IMMOBILE A
fig. 72 ptc. 250 sub 1 – Via Lazio n. 8



DOCUMENTAZIONE FOTOGRAFICA
LOTTO 1 - IMMOBILE A
fig. 72 ptc. 250 sub 1 – Via Lazio n. 8

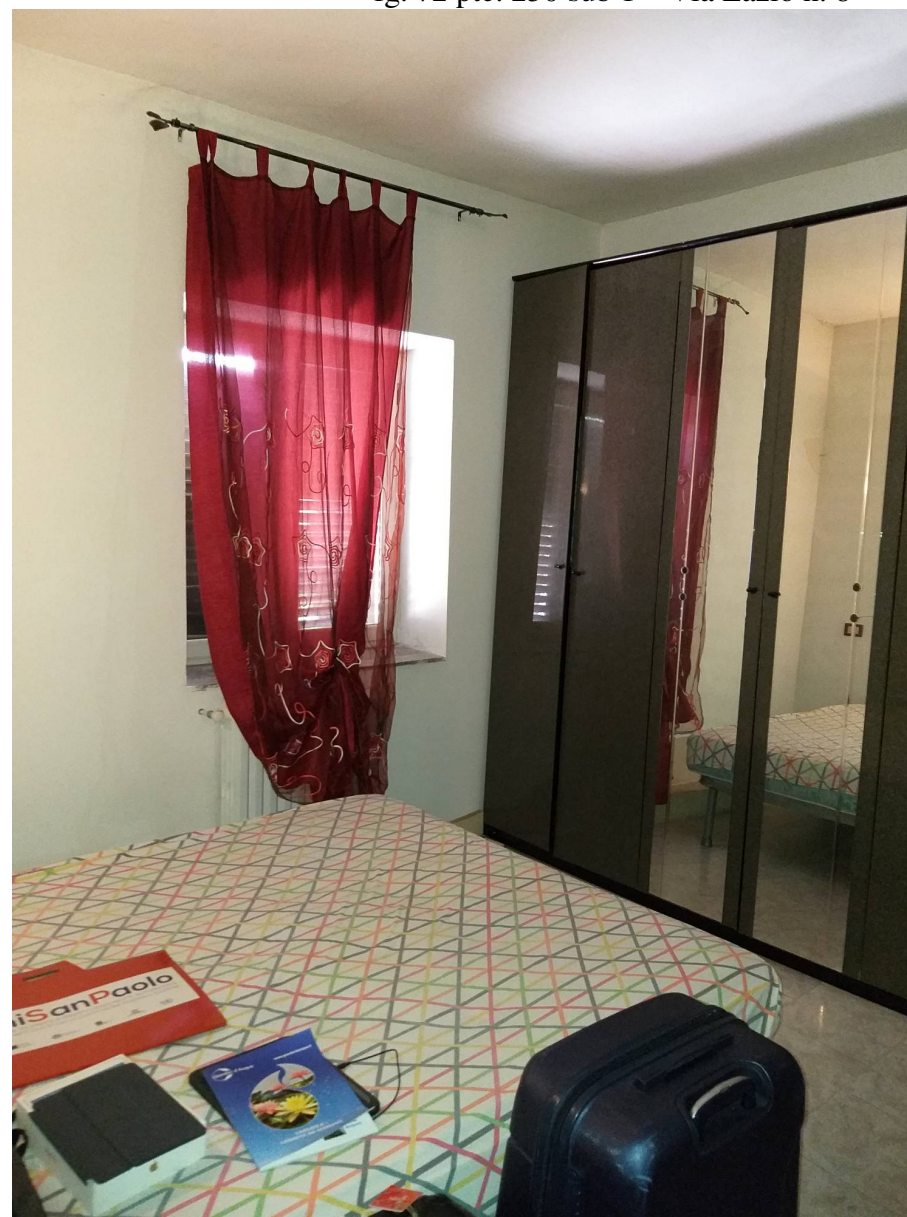

DOCUMENTAZIONE FOTOGRAFICA
LOTTO 1 - IMMOBILE A
fig. 72 pct. 250 sub 1 – Via Lazio n. 8

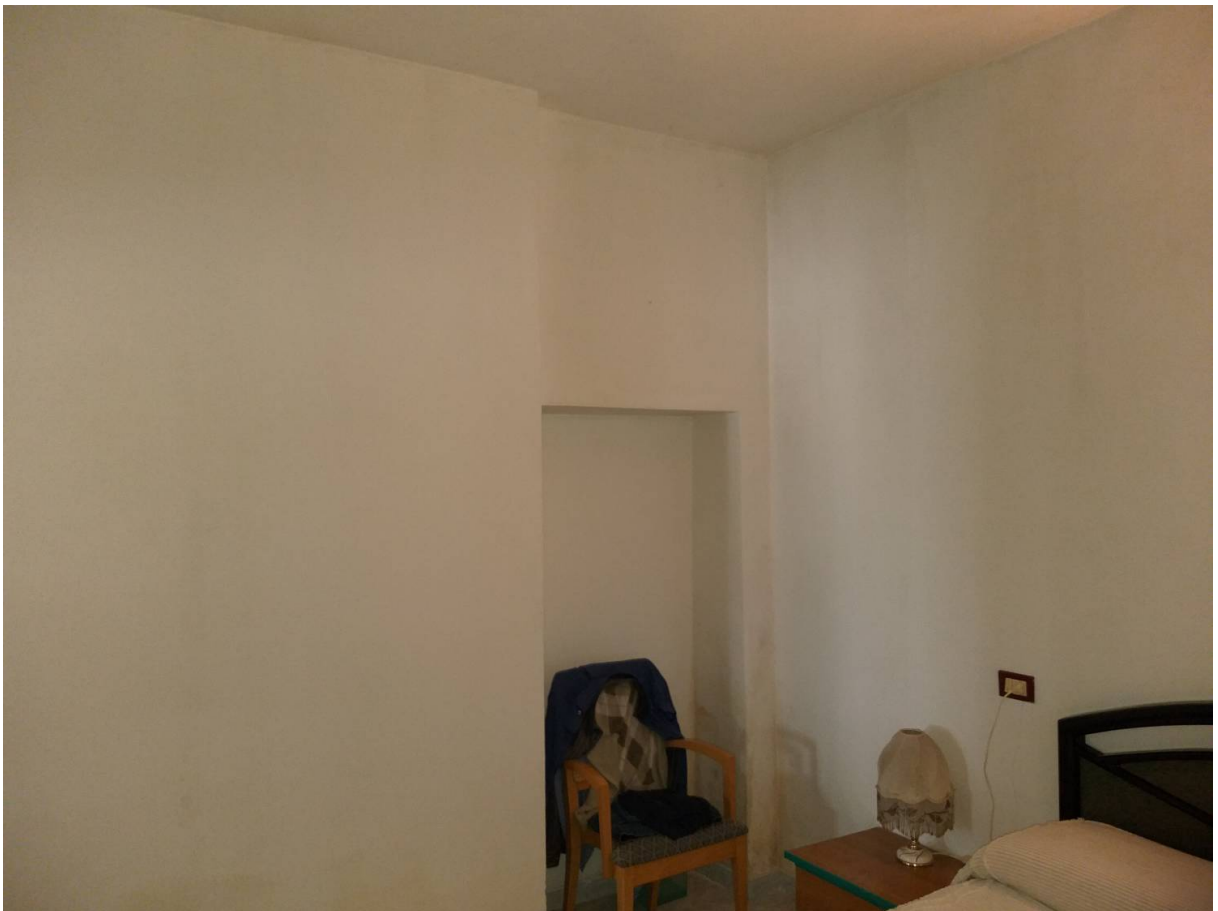



DOCUMENTAZIONE FOTOGRAFICA
LOTTO 1 - IMMOBILE A
fig. 72 ptc. 250 sub 1 – Via Lazio n. 8



DOCUMENTAZIONE FOTOGRAFICA
LOTTO 1 - IMMOBILE A
fig. 72 ptc. 250 sub 1 – Via Lazio n. 8



DOCUMENTAZIONE FOTOGRAFICA
LOTTO 1 - IMMOBILE A
fig. 72 ptc. 250 sub 1 – Via Lazio n. 8



DOCUMENTAZIONE FOTOGRAFICA
LOTTO 1 - IMMOBILE A
fig. 72 ptc. 250 sub 1 – Via Lazio n. 8



DOCUMENTAZIONE FOTOGRAFICA
LOTTO 1 - IMMOBILE A
fig. 72 ptc. 250 sub 1 – Via Lazio n. 8



DOCUMENTAZIONE FOTOGRAFICA
LOTTO 1 - IMMOBILE A
fig. 72 ptc. 250 sub 1 – Via Lazio n. 8



DOCUMENTAZIONE FOTOGRAFICA
LOTTO 1 - IMMOBILE A
fig. 72 ptc. 250 sub 1 – Via Lazio n. 8



DOCUMENTAZIONE FOTOGRAFICA
LOTTO 1 - IMMOBILE A
fig. 72 ptc. 250 sub 1 – Via Lazio n. 8



DOCUMENTAZIONE FOTOGRAFICA
LOTTO 1 - IMMOBILE A
fig. 72 ptc. 250 sub 1 – Via Lazio n. 8



DOCUMENTAZIONE FOTOGRAFICA
LOTTO 1 - IMMOBILE A
fig. 72 ptc. 250 sub 1 – Via Lazio n. 8



DOCUMENTAZIONE FOTOGRAFICA
LOTTO 1 - IMMOBILE A
fig. 72 ptc. 250 sub 1 – Via Lazio n. 8



DOCUMENTAZIONE FOTOGRAFICA
LOTTO 1 - IMMOBILE A
fig. 72 ptc. 250 sub 1 – Via Lazio n. 8



DOCUMENTAZIONE FOTOGRAFICA
LOTTO 1 - IMMOBILE A
fig. 72 pct. 250 sub 1 – Via Lazio n. 8



DOCUMENTAZIONE FOTOGRAFICA
LOTTO 1 - IMMOBILE A
fig. 72 ptc. 250 sub 1 – Via Lazio n. 8



DOCUMENTAZIONE FOTOGRAFICA
LOTTO 1 - IMMOBILE A
fig. 72 pct. 250 sub 1 – Via Lazio n. 8



DOCUMENTAZIONE FOTOGRAFICA
LOTTO 1 - IMMOBILE A
fig. 72 pct. 250 sub 1 – Via Lazio n. 8



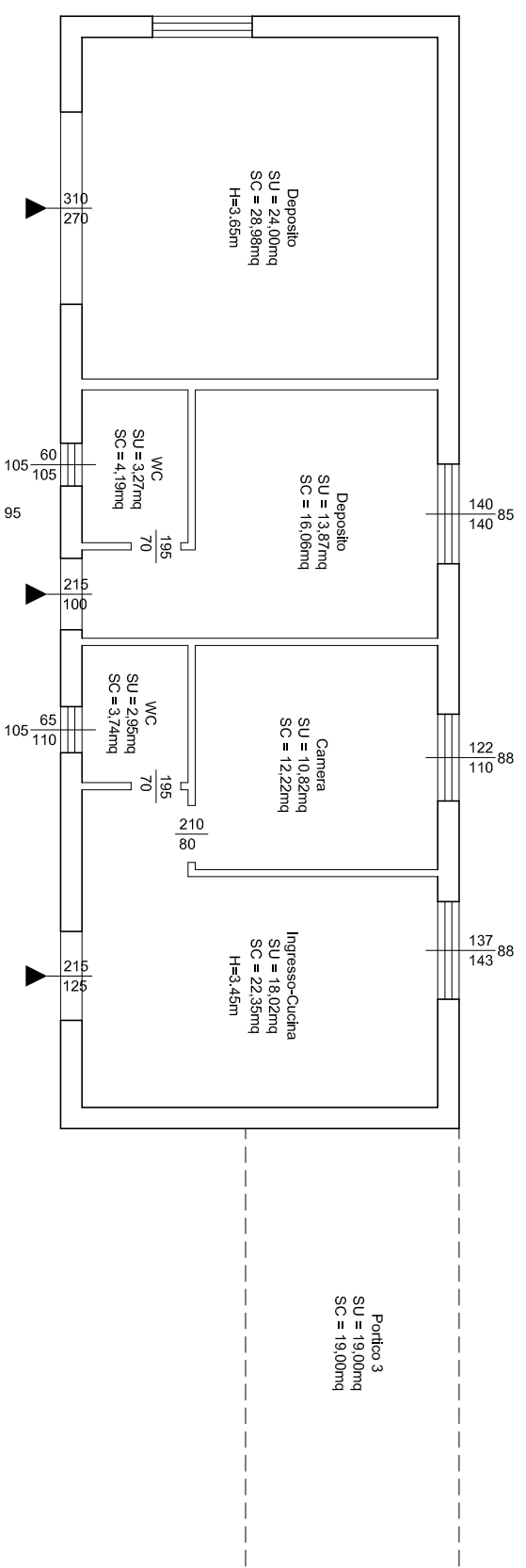
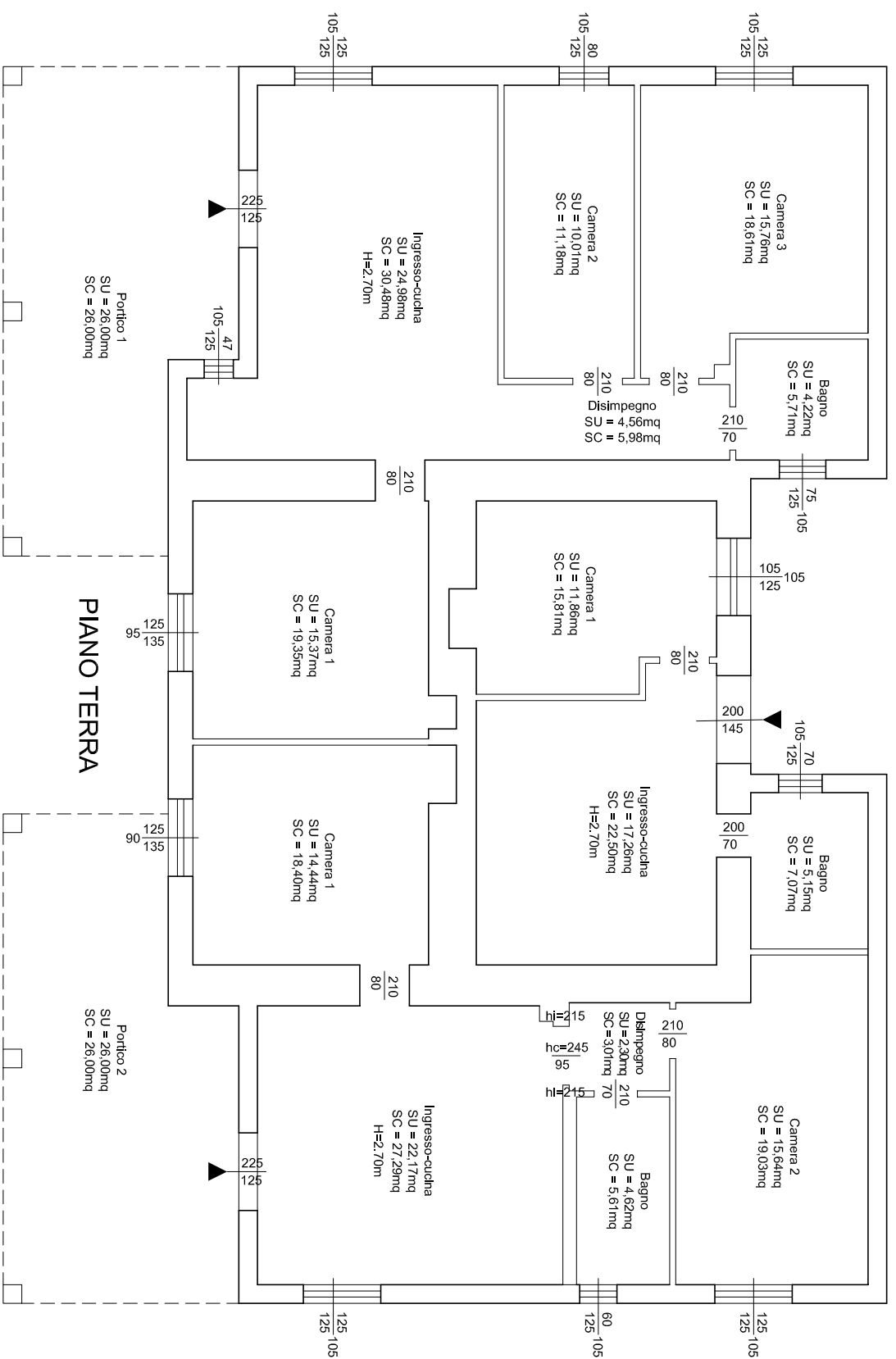

PIANO TERRA

**SCOSTAMENTI PERCENTUALI DALLE CARATTERISTICHE
DI GRADO MEDIO DEGLI ELEMENTI APPREZZATI DAL MERCATO**

LOTTO 1: Immobile A

1 - EDIFICIO		
ELEMENTI	GIUDIZIO/DESCRIZIONE	VALORE
TIPOLOGIA	produttivo	1
ETA' DI COSTRUZIONE	anni '50	0
SISTEMA COSTRUTTIVO	muratura	0
FACCIAE ESTERNE	intonacate	0
TOTALE K1		1

2 - CARATTERISTICHE POSIZIONALI INTRINSECHE		
ELEMENTI	GIUDIZIO/DESCRIZIONE	VALORE
POSIZIONE	agricola	0
PIANO	terra	0
PANORAMICITA'	buona	0
LUMINOSITA'	buona	0
ESPOSIZIONE	quattro lati	1
RUMOROSITA'	scarsa	1
TOTALE K2		2

3 - CARATTERISTICHE INTERNE		
ELEMENTI	GIUDIZIO/DESCRIZIONE	VALORE
ALTEZZA	buona	0
DISTRIBUZIONE AMBIENTI	buona	0
PAVIMENTI E RIVESTIMENTI	buona	0
RIFINITURE E TINTEGGIATURE	buona	0
INFISSI INTERNI	buona	0
INFISSI ESTERNI	buona	0
IMPIANTO TERMICO	buona	0
IMPIANTO ELETTRICO	buona	0
IMPIANTO IDRICO SANITARIO	buona	0
TOTALE K3		0

4 - STATO DI MANUTENZIONE CARATTERISTICHE INTERNE		
ELEMENTI	GIUDIZIO/DESCRIZIONE	VALORE
PAVIMENTI E RIVESTIMENTI	buono	0
RIFINITURE E TINTEGGIATURE	buono	0
INFISSI INTERNI	buono	0
INFISSI ESTERNI	buono	0
IMPIANTO TERMICO	buono	0
IMPIANTO ELETTRICO	buono	0
IMPIANTO IDRICO SANITARIO	buono	0
TOTALE K4		0

5 - DOTAZIONE DI SERVIZI		
ELEMENTI	GIUDIZIO/DESCRIZIONE	VALORE
ACCESSO INDIPENDENTE	autonomo	1
PARCHEGGI	presenti	0
TOTALE K5		1

SOMMA COEFFICIENTI **4**



DOCUMENTAZIONE FOTOGRAFICA
LOTTO 2 - IMMOBILE B
fig. 60 ptc. 24 sub 60 – Via E. Berlinguer n. 14



DOCUMENTAZIONE FOTOGRAFICA
LOTTO 2 - IMMOBILE B
fg. 60 ptc. 24 sub 60 – Via E. Berlinguer n. 14

PLANIMETRIA DI RILIEVO
LOTTO B: IMMOBILE -B-
(foglio 60 - ptc. 24 sub 60)
Pianta 1:100

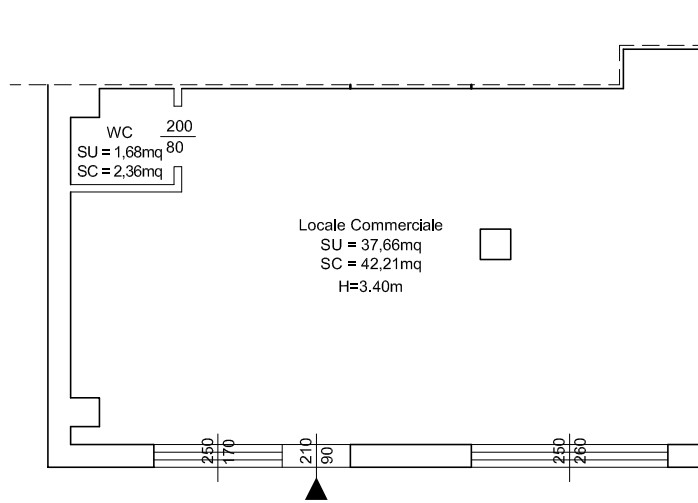

PIANO TERRA

**SCOSTAMENTI PERCENTUALI DALLE CARATTERISTICHE
DI GRADO MEDIO DEGLI ELEMENTI APPREZZATI DAL MERCATO**

LOTTO 2: Immobile B

1 - EDIFICIO		
ELEMENTI	GIUDIZIO/DESCRIZIONE	VALORE
TIPOLOGIA	locale commerciale	1
ETA' DI COSTRUZIONE	anni '80	0
SISTEMA COSTRUTTIVO	c.a.	0
FACCIAE ESTERNE	intonacate	0
TOTALE K1		1

2 - CARATTERISTICHE POSIZIONALI INTRINSECHE		
ELEMENTI	GIUDIZIO/DESCRIZIONE	VALORE
POSIZIONE	centrale	8
PIANO	terra	0
PANORAMICITA'	buona	0
LUMINOSITA'	buona	0
ESPOSIZIONE	un lato	1
RUMOROSITA'	scarsa	1
TOTALE K2		10

3 - CARATTERISTICHE INTERNE		
ELEMENTI	GIUDIZIO/DESCRIZIONE	VALORE
ALTEZZA	buona	0
DISTRIBUZIONE AMBIENTI	buona	0
PAVIMENTI E RIVESTIMENTI	buona	1
RIFINITURE E TINTEGGIATURE	buona	1
INFISSI INTERNI	buona	1
INFISSI ESTERNI	buona	1
IMPIANTO TERMICO	buona	0
IMPIANTO ELETTRICO	buona	0
IMPIANTO IDRICO SANITARIO	buona	0
TOTALE K3		4

4 - STATO DI MANUTENZIONE CARATTERISTICHE INTERNE		
ELEMENTI	GIUDIZIO/DESCRIZIONE	VALORE
PAVIMENTI E RIVESTIMENTI	buono	0
RIFINITURE E TINTEGGIATURE	buono	0
INFISSI INTERNI	buono	1
INFISSI ESTERNI	buono	1
IMPIANTO TERMICO	buono	0
IMPIANTO ELETTRICO	buono	1
IMPIANTO IDRICO SANITARIO	buono	1
TOTALE K4		4

5 - DOTAZIONE DI SERVIZI		
ELEMENTI	GIUDIZIO/DESCRIZIONE	VALORE
ACCESSO INDIPENDENTE	autonomo	0
PARCHEGGI	presenti	2
TOTALE K5		2

SOMMA COEFFICIENTI **21**

DOCUMENTAZIONE FOTOGRAFICA
LOTTO 3 - IMMOBILE C
Fig. 60 pct. 772 sub 6 e 8 – Piazza Giuseppe Verdi



DOCUMENTAZIONE FOTOGRAFICA
LOTTO 3 - IMMOBILE C
Fig. 60 pct. 772 sub 6 e 8 – Piazza Giuseppe Verdi



DOCUMENTAZIONE FOTOGRAFICA
LOTTO 3 - IMMOBILE C
Fig. 60 pct. 772 sub 6 e 8 – Piazza Giuseppe Verdi

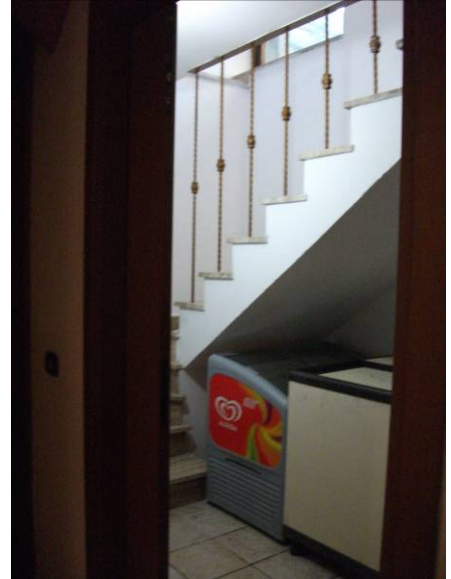
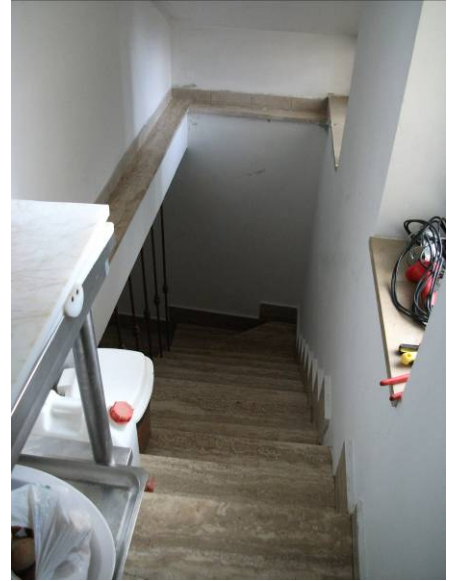

DOCUMENTAZIONE FOTOGRAFICA
LOTTO 3 - IMMOBILE C
Fig. 60 pct. 772 sub 6 e 8 – Piazza Giuseppe Verdi

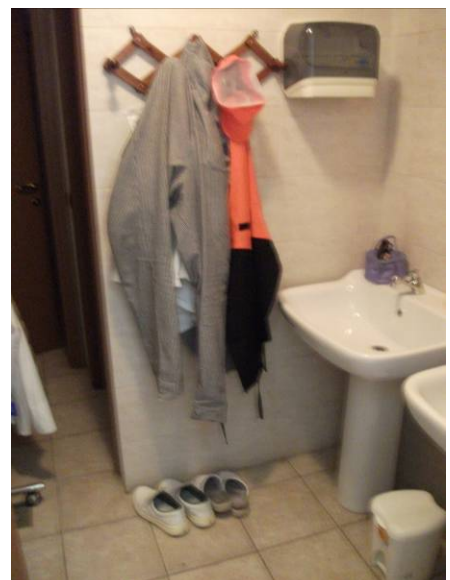
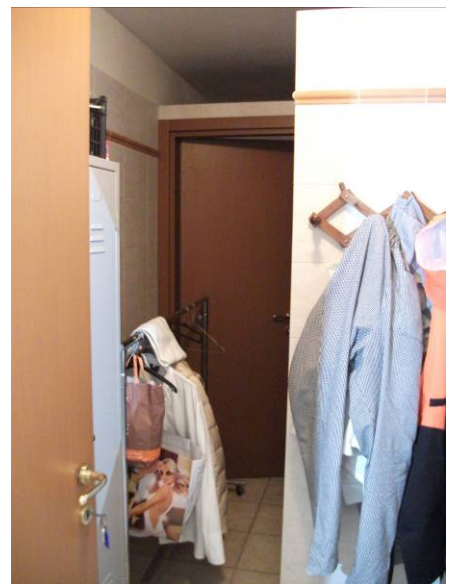
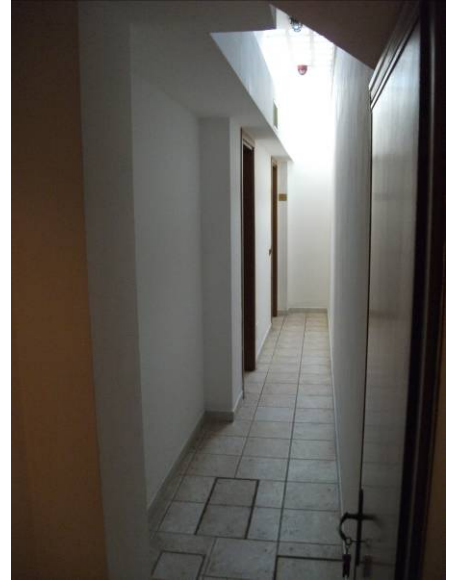

DOCUMENTAZIONE FOTOGRAFICA
LOTTO 3 - IMMOBILE C
Fig. 60 pct. 772 sub 6 e 8 – Piazza Giuseppe Verdi



DOCUMENTAZIONE FOTOGRAFICA
LOTTO 3 - IMMOBILE C
Fig. 60 pct. 772 sub 6 e 8 – Piazza Giuseppe Verdi

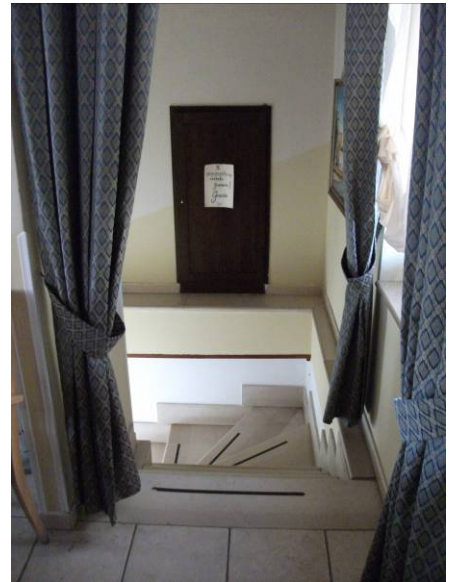
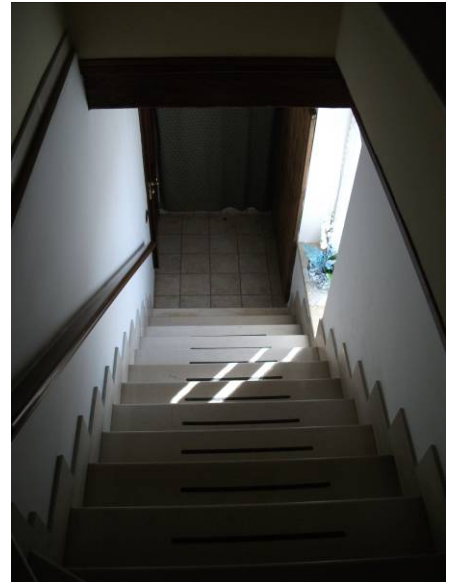

DOCUMENTAZIONE FOTOGRAFICA
LOTTO 3 - IMMOBILE C
Fig. 60 pct. 772 sub 6 e 8 – Piazza Giuseppe Verdi

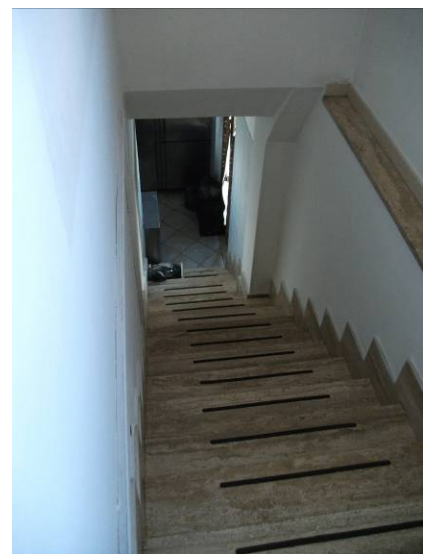
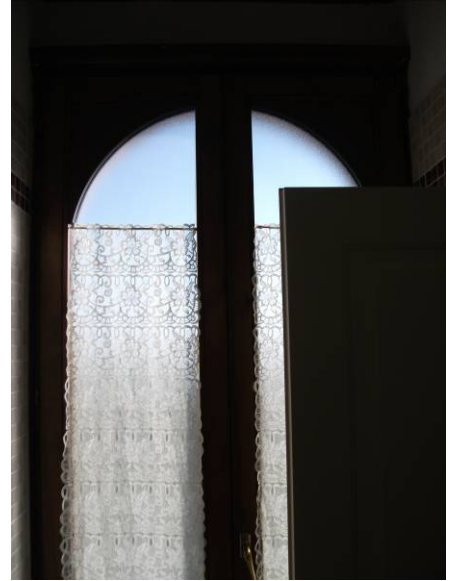

DOCUMENTAZIONE FOTOGRAFICA
LOTTO 3 - IMMOBILE C
Fig. 60 pct. 772 sub 6 e 8 – Piazza Giuseppe Verdi

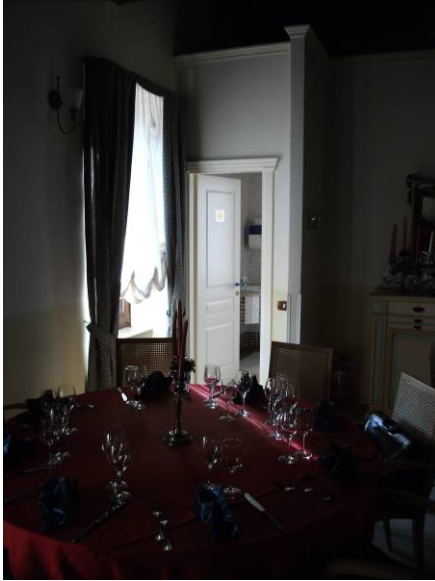

PIANO INTERRATO

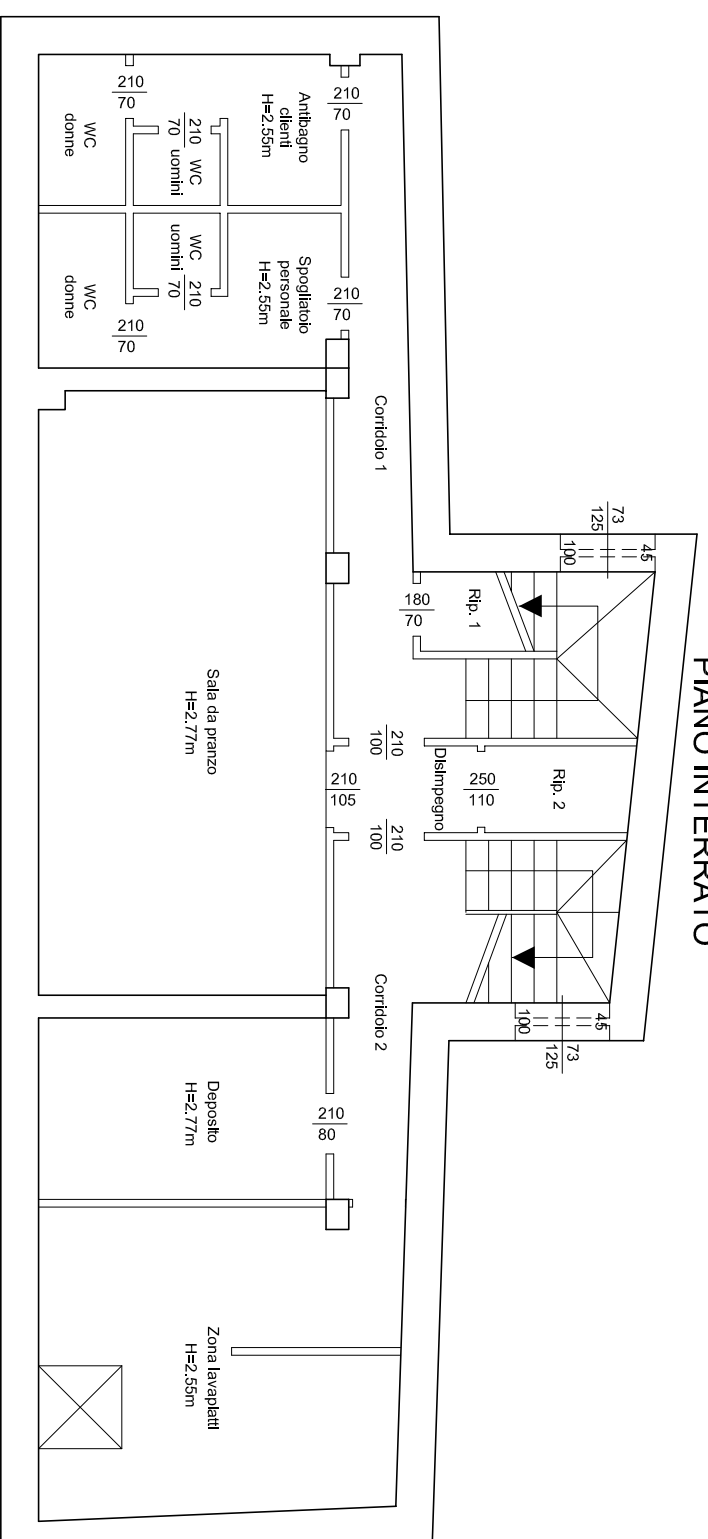

PLANIMETRIA DI RILEVO
LOTTO C: IMMOBILE -C-
(foglio 60 - ptc. 742 sub 6 e 8)
Pianta 1:100

PIANO TERRA

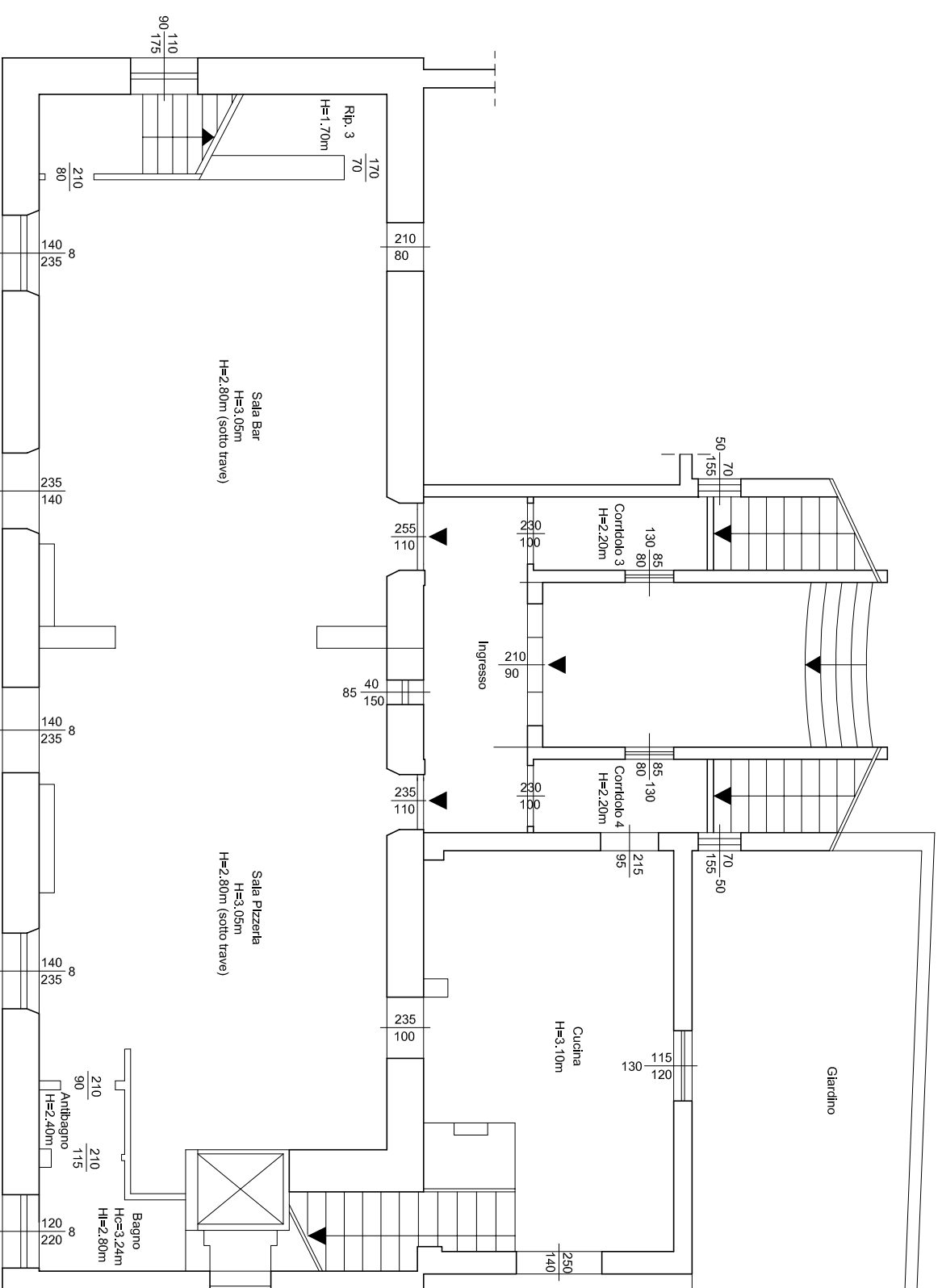

**SCOSTAMENTI PERCENTUALI DALLE CARATTERISTICHE
DI GRADO MEDIO DEGLI ELEMENTI APPREZZATI DAL MERCATO**

LOTTO 3: Immobile C

1 - EDIFICIO		
ELEMENTI	GIUDIZIO/DESCRIZIONE	VALORE
TIPOLOGIA	locale commerciale	1
ETA' DI COSTRUZIONE	primi del '900	0
SISTEMA COSTRUTTIVO	muratura	0
FACCIAE ESTERNE	intonacate	0
TOTALE K1		1

2 - CARATTERISTICHE POSIZIONALI INTRINSECHE		
ELEMENTI	GIUDIZIO/DESCRIZIONE	VALORE
POSIZIONE	centrale nella zona di riferimento	8
PIANO	interrato, terra e primo	0
PANORAMICITA'	buona	0
LUMINOSITA'	buona	0
ESPOSIZIONE	quattro lati	1
RUMOROSITA'	scarsa	1
TOTALE K2		10

3 - CARATTERISTICHE INTERNE		
ELEMENTI	GIUDIZIO/DESCRIZIONE	VALORE
ALTEZZA	buona	0
DISTRIBUZIONE AMBIENTI	buona	0
PAVIMENTI E RIVESTIMENTI	buona	1
RIFINITURE E TINTEGGIATURE	buona	1
INFISSI INTERNI	buona	1
INFISSI ESTERNI	buona	1
IMPIANTO TERMICO	buona	0
IMPIANTO ELETTRICO	buona	0
IMPIANTO IDRICO SANITARIO	buona	0
TOTALE K3		4

4 - STATO DI MANUTENZIONE CARATTERISTICHE INTERNE		
ELEMENTI	GIUDIZIO/DESCRIZIONE	VALORE
PAVIMENTI E RIVESTIMENTI	buono	1
RIFINITURE E TINTEGGIATURE	buono	1
INFISSI INTERNI	buono	1
INFISSI ESTERNI	buono	1
IMPIANTO TERMICO	buono	0
IMPIANTO ELETTRICO	buono	0
IMPIANTO IDRICO SANITARIO	buono	0
TOTALE K4		4

5 - DOTAZIONE DI SERVIZI		
ELEMENTI	GIUDIZIO/DESCRIZIONE	VALORE
ACCESSO INDIPENDENTE	autonomo	0
PARCHEGGI	presenti	2
TOTALE K5		2

SOMMA COEFFICIENTI **21**

DOCUMENTAZIONE FOTOGRAFICA
LOTTO 4 - IMMOBILE D
Fig. 60 ptc. 742 sub 7 – Piazza Giuseppe Verdi



DOCUMENTAZIONE FOTOGRAFICA
LOTTO 4 - IMMOBILE D
Fig. 60 ptc. 742 sub 7 – Piazza Giuseppe Verdi

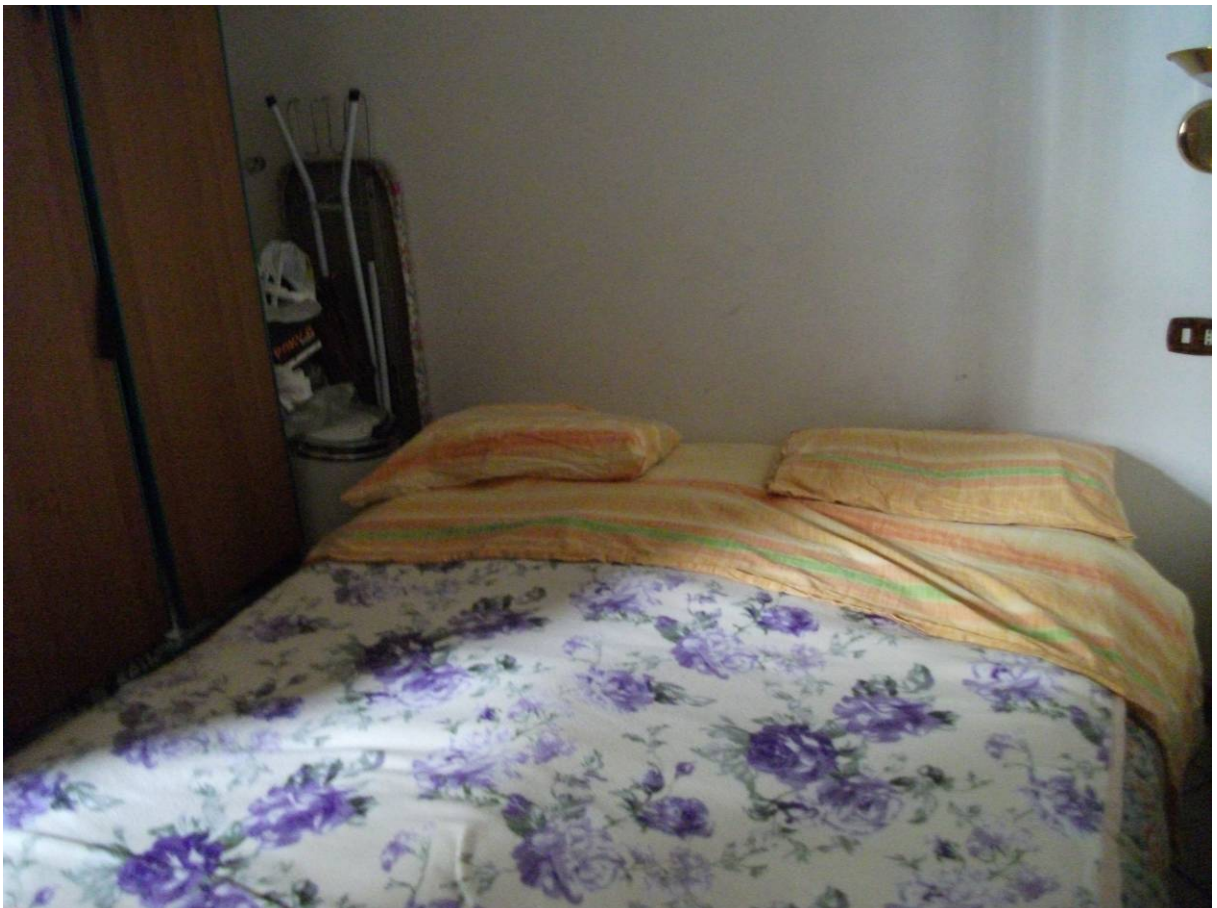

DOCUMENTAZIONE FOTOGRAFICA
LOTTO 4 - IMMOBILE D
Fig. 60 ptc. 742 sub 7 – Piazza Giuseppe Verdi

DOCUMENTAZIONE FOTOGRAFICA
LOTTO 4 - IMMOBILE D
Fig. 60 ptc. 742 sub 7 – Piazza Giuseppe Verdi

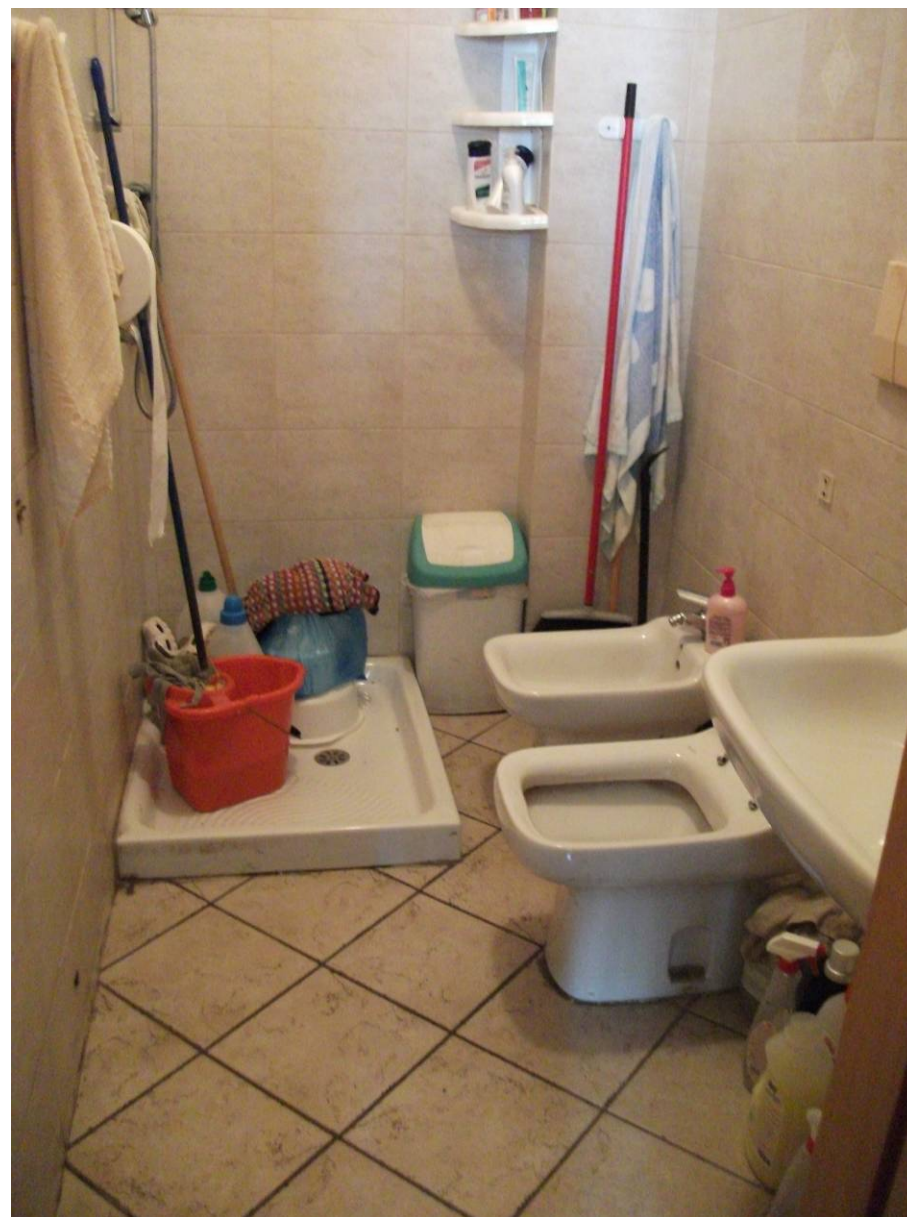
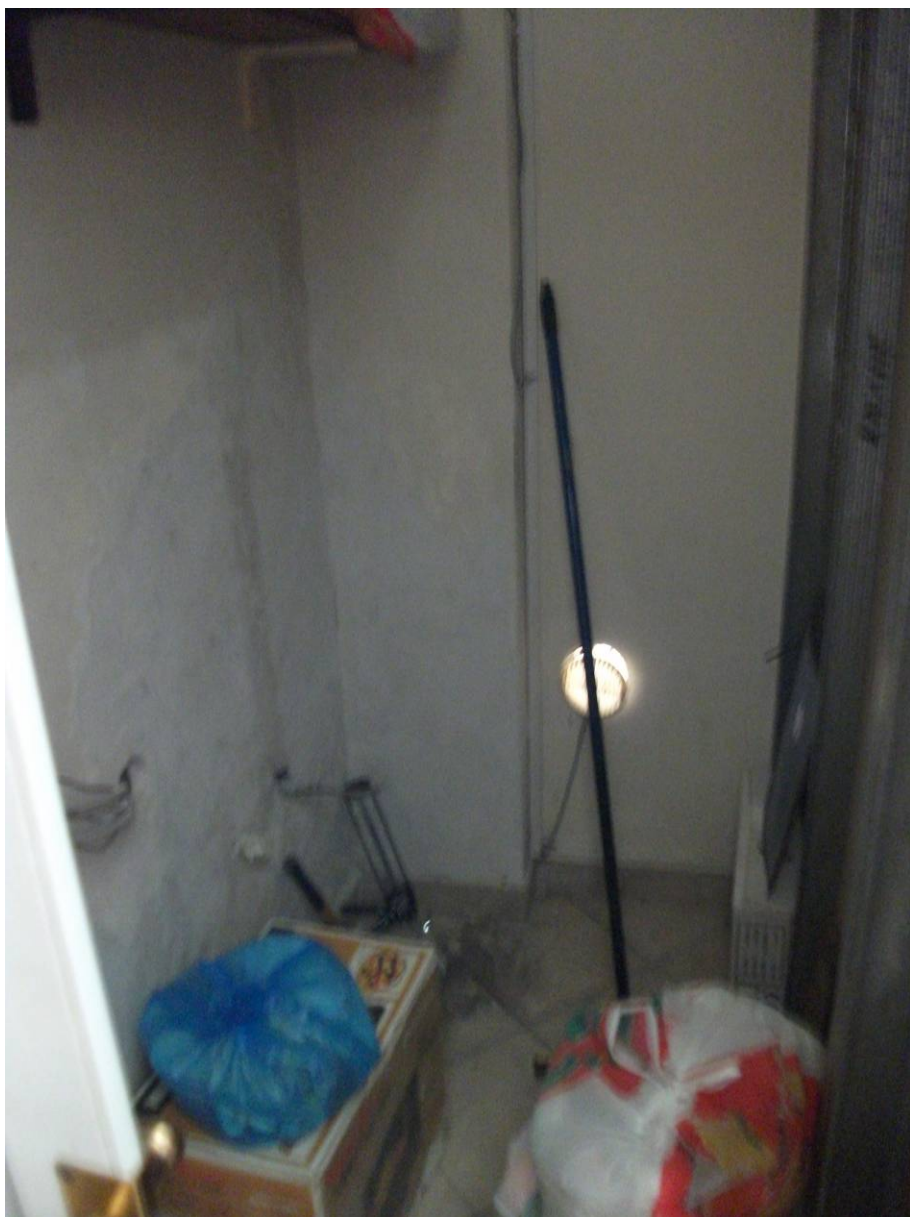

DOCUMENTAZIONE FOTOGRAFICA
LOTTO 4 - IMMOBILE D
Fig. 60 ptc. 742 sub 7 – Piazza Giuseppe Verdi

PLANIMETRIA DI RILIEVO
LOTTO D: IMMOBILE -D-
(foglio 60 - ptc. 742 sub 7)
Pianta 1:100

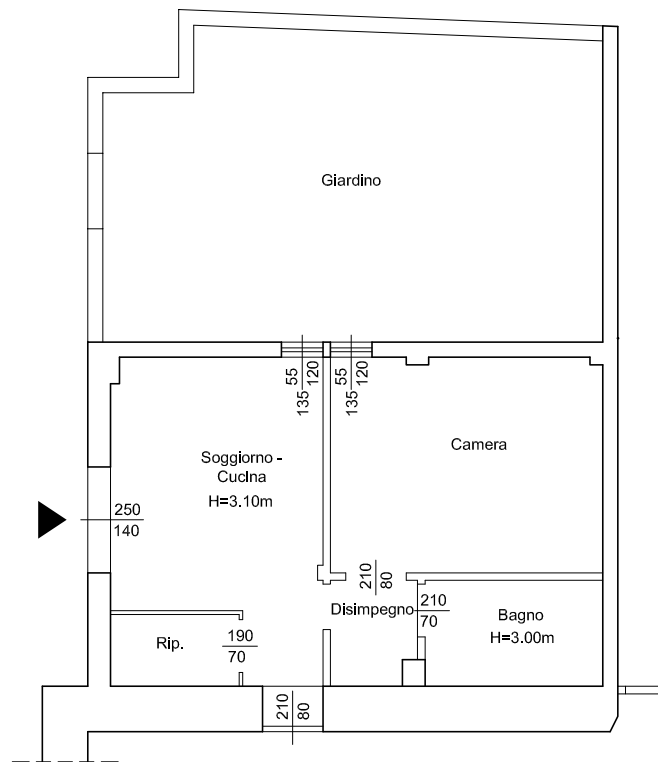

PIANO TERRA

**SCOSTAMENTI PERCENTUALI DALLE CARATTERISTICHE
DI GRADO MEDIO DEGLI ELEMENTI APPREZZATI DAL MERCATO**

LOTTO 4: Immobile D

1 - EDIFICIO		
ELEMENTI	GIUDIZIO/DESCRIZIONE	VALORE
TIPOLOGIA	appartamento	0
ETA' DI COSTRUZIONE	primi del '900	0
SISTEMA COSTRUTTIVO	muratura	0
FACCIAE ESTERNE	intonacata	0
TOTALE K1		0

2 - CARATTERISTICHE POSIZIONALI INTRINSECHE		
ELEMENTI	GIUDIZIO/DESCRIZIONE	VALORE
POSIZIONE	centrale nella zona di riferimento	8
PIANO	terra	0
PANORAMICITA'	sufficiente	0
LUMINOSITA'	sufficiente	0
ESPOSIZIONE	due lati	0
RUMOROSITA'	scarsa	2
TOTALE K2		10

3 - CARATTERISTICHE INTERNE		
ELEMENTI	GIUDIZIO/DESCRIZIONE	VALORE
ALTEZZA	buona	0
DISTRIBUZIONE AMBIENTI	buono	1
PAVIMENTI E RIVESTIMENTI	sufficiente	0
RIFINITURE E TINTEGGIATURE	sufficiente	0
INFISSI INTERNI	sufficiente	0
INFISSI ESTERNI	buono	1
IMPIANTO TERMICO	buono	1
IMPIANTO ELETTRICO	buono	1
IMPIANTO IDRICO SANITARIO	buono	1
TOTALE K3		5

4 - STATO DI MANUTENZIONE CARATTERISTICHE INTERNE		
ELEMENTI	GIUDIZIO/DESCRIZIONE	VALORE
PAVIMENTI E RIVESTIMENTI	sufficiente	0
RIFINITURE E TINTEGGIATURE	sufficiente	0
INFISSI INTERNI	sufficiente	0
INFISSI ESTERNI	sufficiente	0
IMPIANTO TERMICO	buono	1
IMPIANTO ELETTRICO	buono	1
IMPIANTO IDRICO SANITARIO	buono	1
TOTALE K4		3

5 - DOTAZIONE DI SERVIZI		
ELEMENTI	GIUDIZIO/DESCRIZIONE	VALORE
ACCESSO INDIPENDENTE	autonomo	0
TOTALE K5		0

SOMMA COEFFICIENTI **18**