

**ALLEGATO 3** – DOCUMENTAZIONE GRAFICA  
(ELABORATI A SUPPORTO DELLO STUDIO)

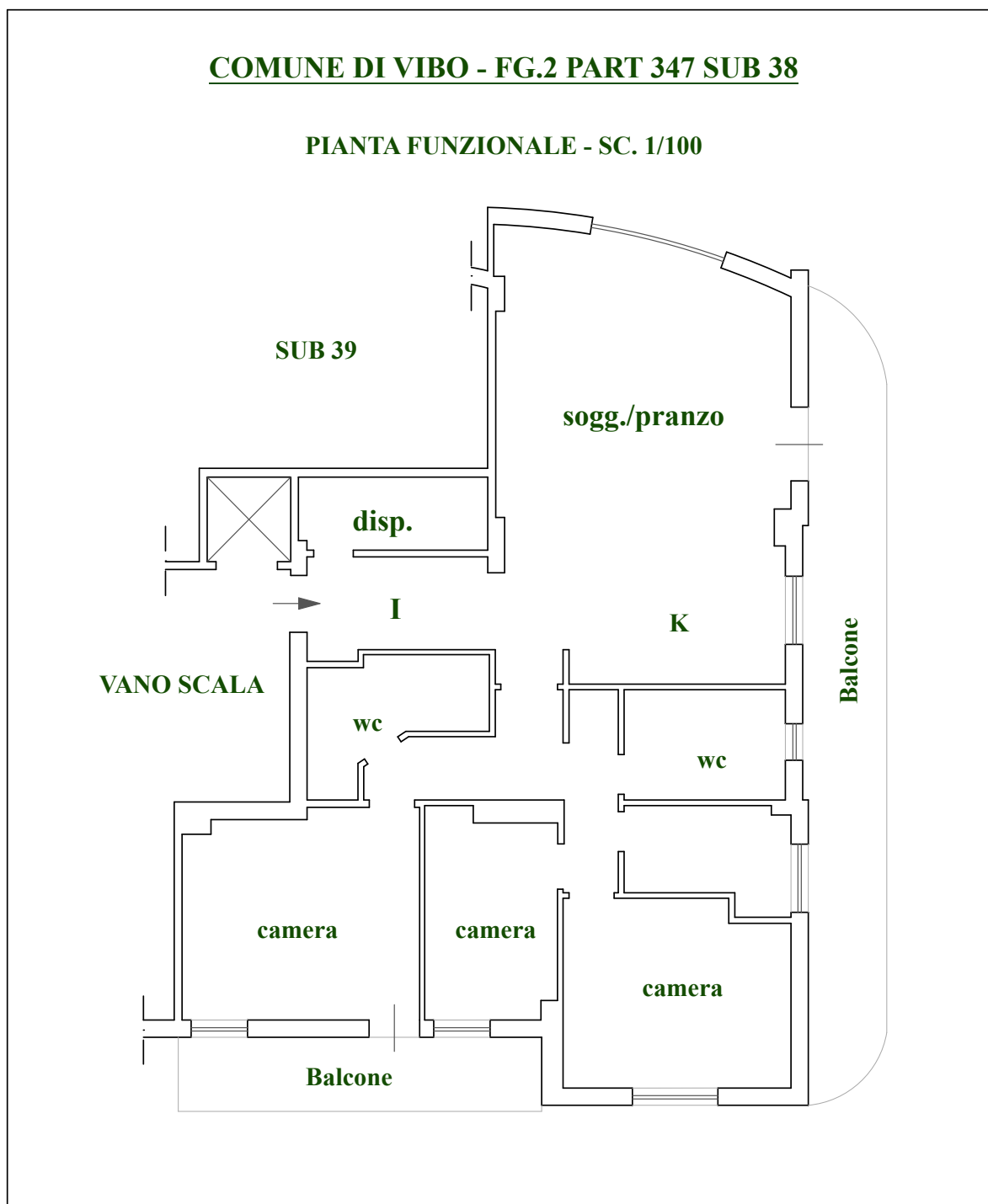

**COMUNE DI VIBO - FG.2 PART 347 SUB 38**

**PIANTA QUOTATA - SC. 1/100**

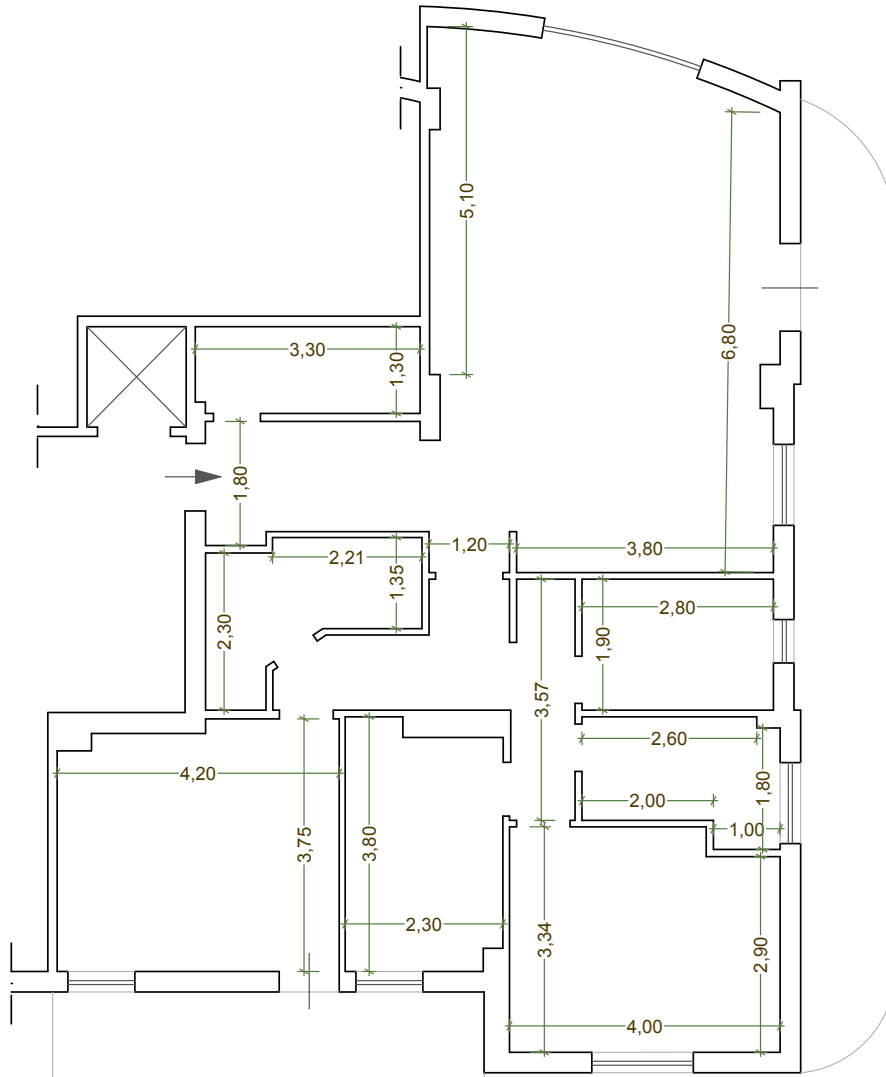

**COMUNE DI VIBO - FG.2 PART 347 SUB 38**

**PIANTA DIMENSIONALE - SC. 1/100**

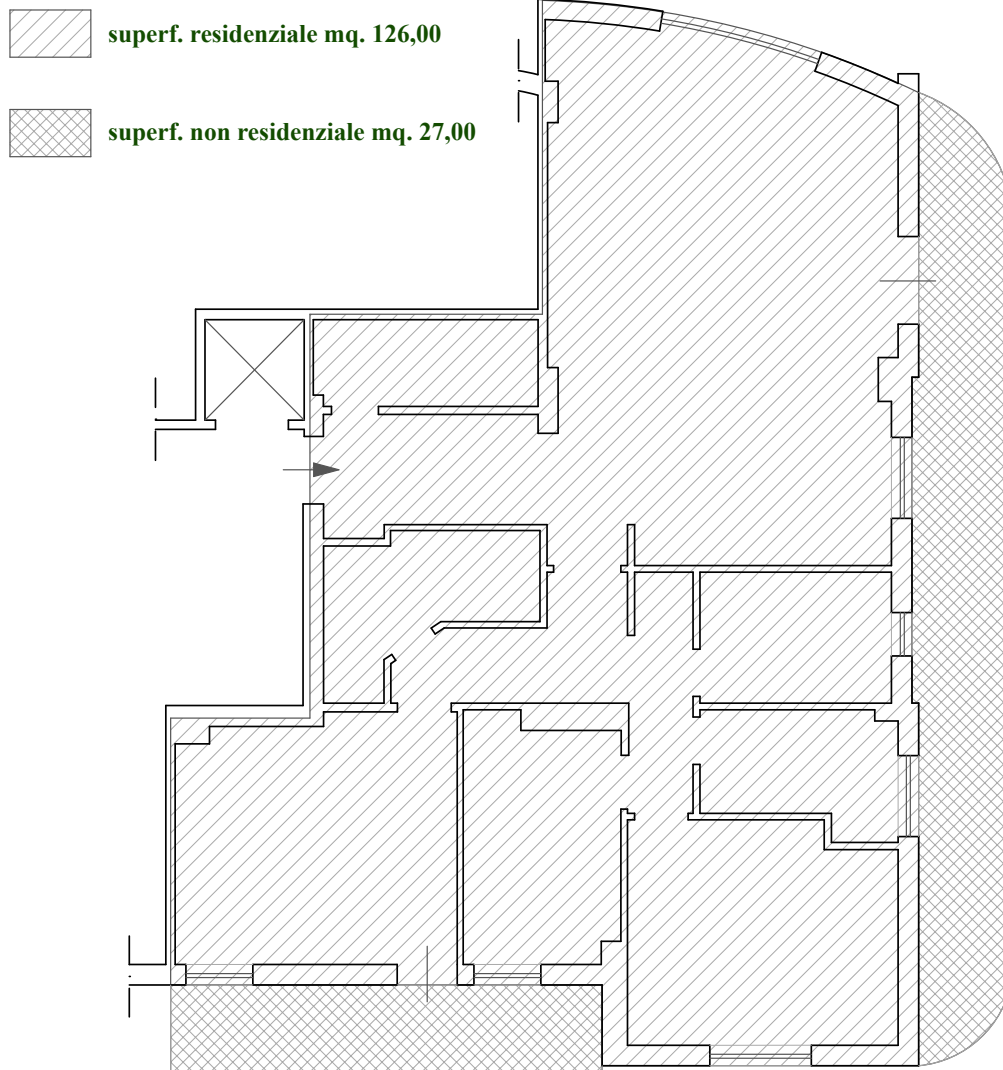

**COMUNE DI VIBO - FG.2 PART 347 SUB 39**

**PIANTA FUNZIONALE - SC. 1/100**

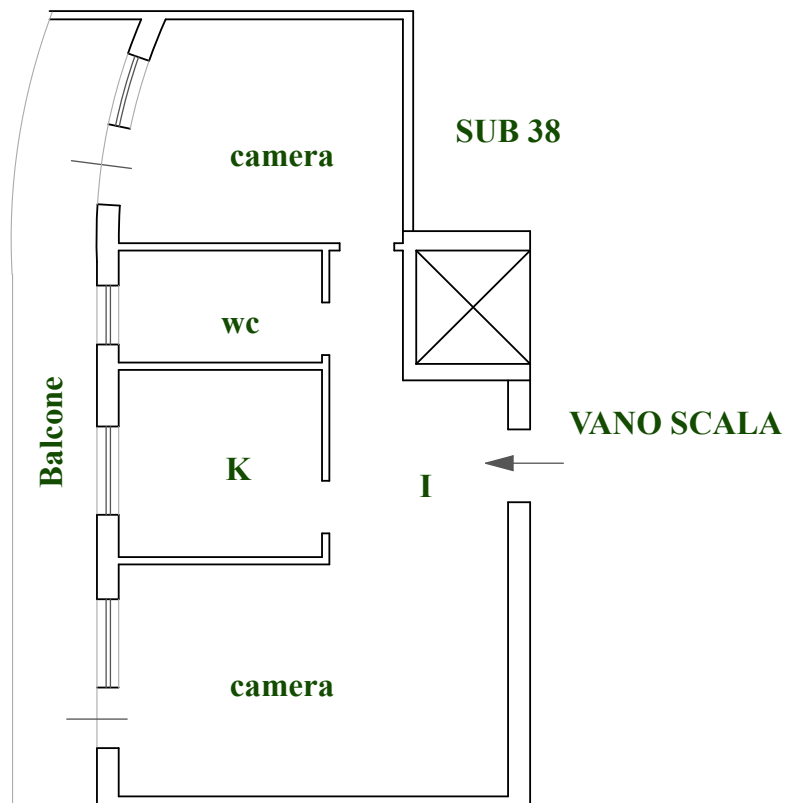

**COMUNE DI VIBO - FG.2 PART 347 SUB 39**

**PIANTA QUOTATA - SC. 1/100**

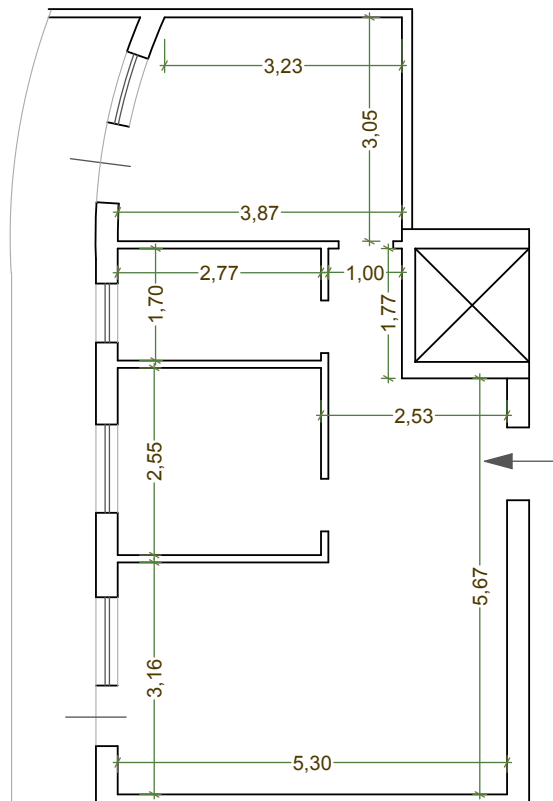

**COMUNE DI VIBO - FG.2 PART 347 SUB 39**

**PIANTA DIMENSIONALE - SC. 1/100**

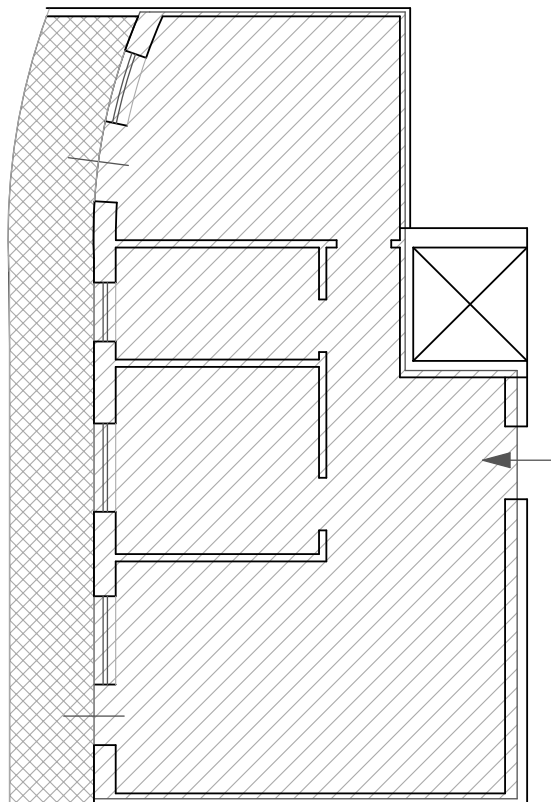

**superf. residenziale mq. 54,00**



**superf. non residenziale mq. 12,00**